

SolarEdge Residential Offering for Installers



solar**edge**

SolarEdge Fact Sheet

About us

In 2006, SolarEdge revolutionised the solar industry by inventing a better way to collect and manage energy in PV systems. Today, we are a global leader in smart energy technology. By deploying world-class engineering capabilities and with a relentless focus on innovation, we create smart energy products and solutions that power our lives and drive future progress.

Vision

We believe that continuous improvement in the ways we produce and manage the energy we consume will lead to a better future for us all.



Bankability

- Approved by major banks and financial institutions worldwide
- SolarEdge (SEDG) is traded on NASDAQ
- Our financial strength and stability, combined with our cutting-edge technology, has propelled us to become one of the largest inverter manufacturers in the world

Global outreach

- Systems installed in over 130 countries across five continents
- Sales via leading integrators and distributors
- Follow the sun call centers
- Local teams of sales, service, marketing, and training experts
- Global manufacturing capabilities with tier 1 electronic manufacturing service companies



Received nearly 30 awards from prestigious organisations including Red Herring, Frost & Sullivan, Intersolar, the Stratus Award, and the Edison Awards™.

Shipping since 2010

- Over 2 million inverters shipped worldwide
- SolarEdge's monitoring platform continuously tracks over a million installations across the globe

Corporate social responsibility

As a global leader in smart energy technologies, SolarEdge is committed to a sustainable world and is in full compliance with international standards on quality and control, ethical conduct, and environmental protection.



Patents

SolarEdge has a vast portfolio of intellectual property, with hundreds of awarded patents and patent applications

Product reliability

- 25-year power optimiser warranty and 12-year inverter warranty, extendable to 20 or 25 years
- SolarEdge products and components undergo rigorous testing, and have been evaluated in accelerated life chambers
- Reliability strategy includes proprietary application specific ICs (ASIC)

The Complete SolarEdge Residential Solution

Monitoring platform

- View real-time system and module performance, and receive notifications on mobile devices
- Visibility of energy production, energy consumption, and battery charge level
- Two dedicated monitoring apps, for installers and homeowners

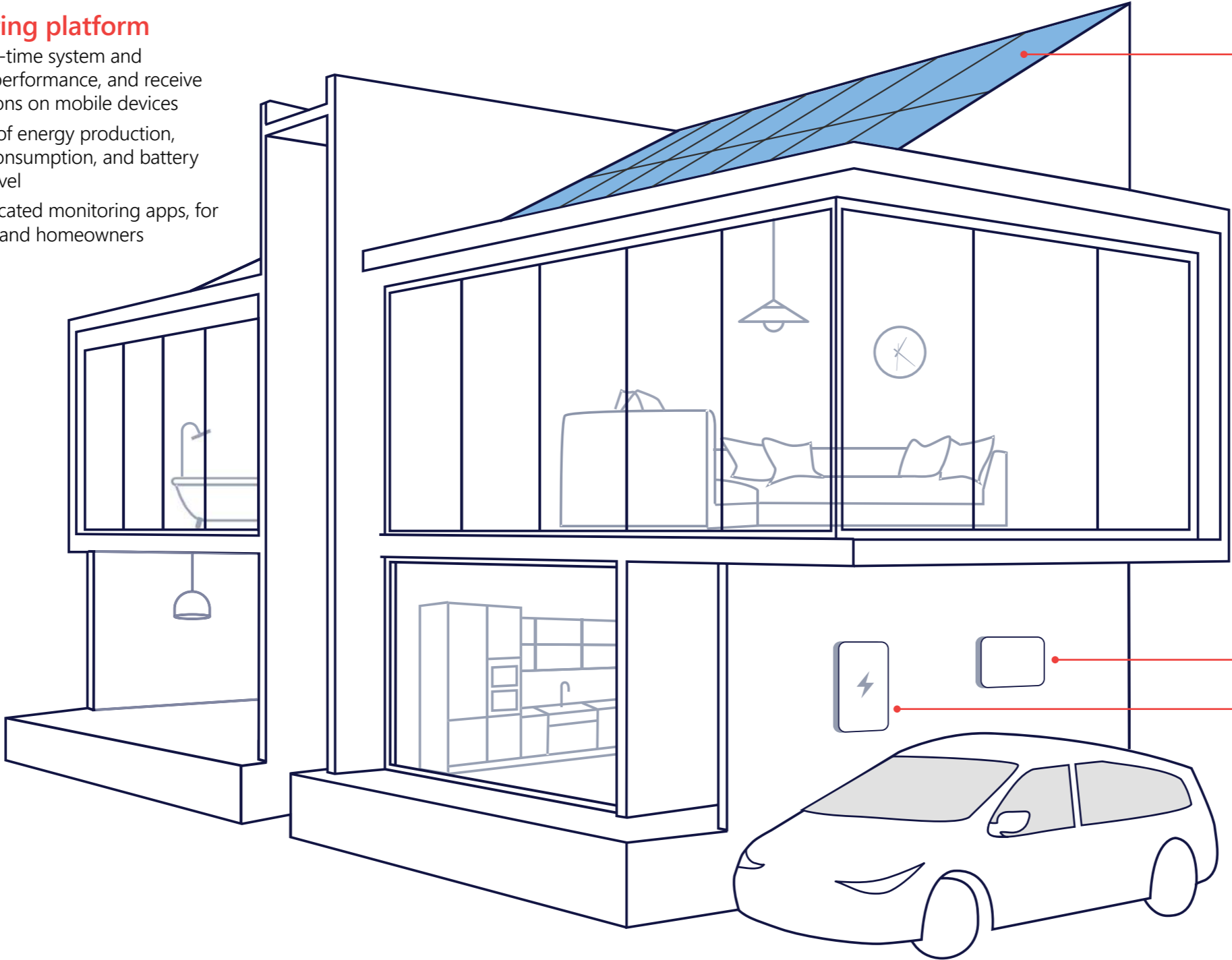

Power optimiser

- Connects to each solar module on the roof to maximise their individual performance
- Provides greater energy production, enhanced safety, and constant information from each module



Inverter

- The brains of the PV system
- Efficiently converts DC energy to AC electricity for use in the home
- Manages system production and battery power



Single phase

Three phase

StorEdge® solution

- Stores PV energy in batteries for use when needed
- Provides backup power for the home during grid outages



More Energy from Each Module

More power equals more revenue and more savings on electricity bills. In traditional string inverter systems, one underperforming module reduces the performance of an entire string.

With SolarEdge, each module produces at its maximum ability at all times, ensuring greater energy yield from the entire system.

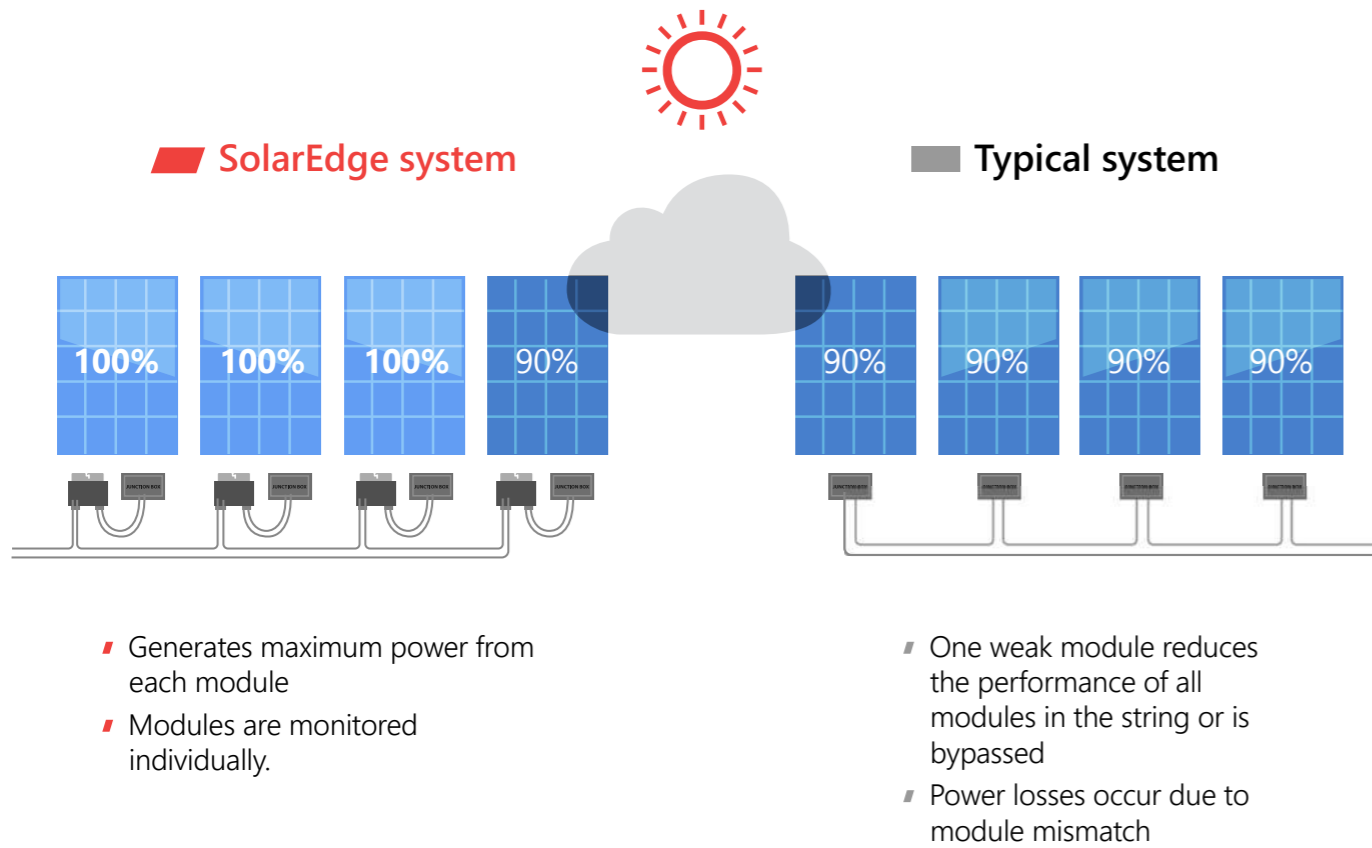

Homeowner value: more energy

More power = more revenue and more savings on your electricity bill. One underperforming solar module connected to a traditional string inverter negatively impacts the performance of an entire string. SolarEdge minimises this issue by allowing each module to perform to the best of its ability at all times.

Power losses can result from:

Manufacturing tolerance mismatch

The warranted output power range for PV modules received from a manufacturing plant may vary greatly. A standard deviation of $\pm 3\%$ is sufficient to result in $\sim 2\%$ energy loss.



Guaranteed power output from module manufacturers 0~+3%

Soiling, shading and leaves

Module soiling, from dirt or bird droppings, contribute to mismatch between modules and strings. While there may be no obstructions during site design, throughout a residential system's lifetime, a tree may grow or a structure may be erected that creates uneven shading.

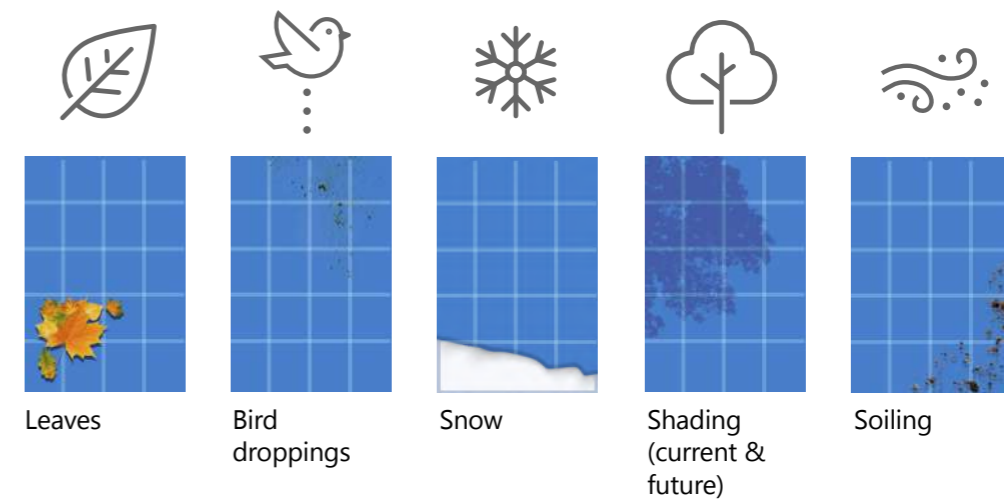

Uneven module aging

Module performance can degrade up to 20% over 20 years, however, each module ages at a different rate, causing aging mismatch, which increases over time.

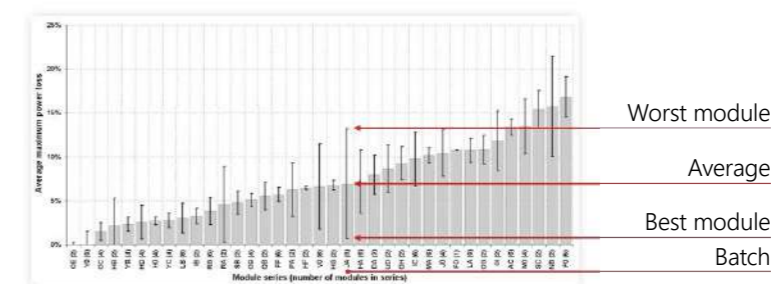

Source: A. Skoczek et. al., "The results of performance measurements of field-aged c-Si photovoltaic modules", Prog. Photovolt: Res. Appl. 2009; 17:227-240

Safe voltage <30 seconds



Advanced Safety

With millions of photovoltaic (PV) systems installed worldwide, this technology is designed to be relatively safe and reliable. However, as traditional PV installations can reach voltages as high as 1,500VDC, precautions should be taken to ensure the safety of people and assets.

With traditional inverters, shutting down the inverter or the grid connection will terminate current flow, but DC voltage in the string cables will stay high for as long as the sun is shining.

In addition, electrical arcs, which can result in a fire, create a threat to people and assets in the vicinity of the PV system.

The SolarEdge system provides a superior safety solution for both electrocution and fire risks.

SafeDC™

SafeDC™ is a built-in module-level safety feature which minimises electrocution risk. To maintain string voltage below risk levels, power optimisers are designed to automatically switch into safety mode, in which the output voltage of each module will be reduced to a safe level in either of these cases:

- During installation, when string is disconnected from the inverter, or the inverter is turned off
- During maintenance or emergency, when the inverter or AC connection is shut down
- When the thermal sensors of the power optimisers detect a temperature above 85 °C



The SolarEdge SafeDC™ feature is certified in Europe as a DC disconnect according to IEC/EN 60947-1 and IEC/EN 60947-3 and to the safety standards VDE AR 2100-712 and OVE R-11-1.

Arc fault detection and interruption

SolarEdge inverters have a built-in protection designed to mitigate the effects of some arcing faults that may pose a risk of fire, in compliance with the UL1699B arc detection standard. Currently there is no comparable arc detection standard in the EU and therefore non-US SolarEdge inverters can detect and interrupt arcs as defined by the UL1699B standard. In addition to manual restart, a mechanism for auto-reconnect can be enabled during system commissioning.

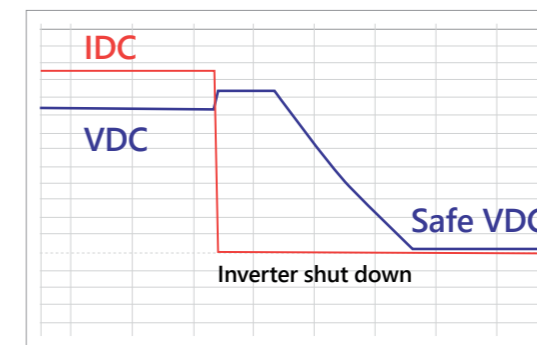

This graph represents an automatic string shutdown. As demonstrated, the current is shut down immediately once AC power or Inverter is turned off. The string voltage is reduced to safe voltage.

Homeowner value: superior safety

For decades now, PV systems have proven to pose minimal safety risks. SolarEdge further improves PV safety with its SafeDC™ feature, designed to reduce your PV system's high voltage to a safe level whenever the grid is shut off, protecting solar professionals, installers, firefighters and your home.

The StorEdge Solution: Enabling Energy Independence

Combining SolarEdge's breakthrough PV inverter technology with leading battery storage systems, the StorEdge solution helps homeowners reduce their electricity bills while maximising energy independence from the grid.



StorEdge is based on a single SolarEdge DC optimised inverter that manages and monitors PV production, consumption and storage. StorEdge is compatible with high voltage LG Chem RESU batteries.

Optimising energy consumption

The StorEdge solution can be used to increase energy independence for homeowners, by utilising a battery to store power and supply power as needed. To optimise self-consumption, the battery is automatically charged and discharged to meet consumption needs and reduce the amount of power purchased from the grid.

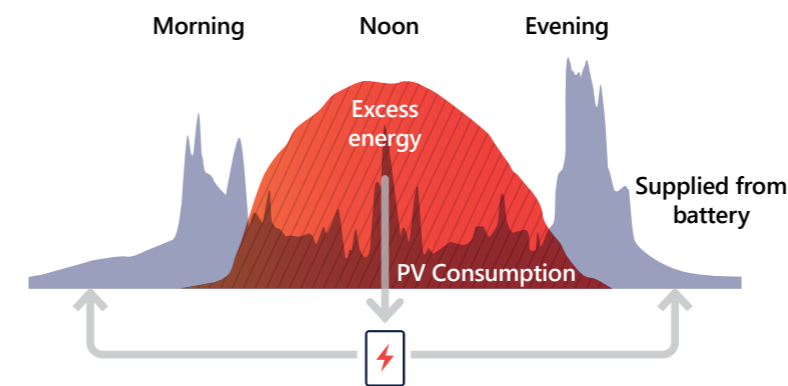

With StorEdge, the excess energy produced during peak sunlight hours is stored to the battery and used later so no energy is ever wasted.

Keeping the lights on when the grid goes down

In addition to optimising self-consumption, StorEdge can also automatically provide backup power to pre-selected loads when the household suffers from grid interruptions. A combination of PV and battery is used to power important loads such as the refrigerator, TV, lights and AC outlets to keep things running smoothly, day or night.

Providing power day or night

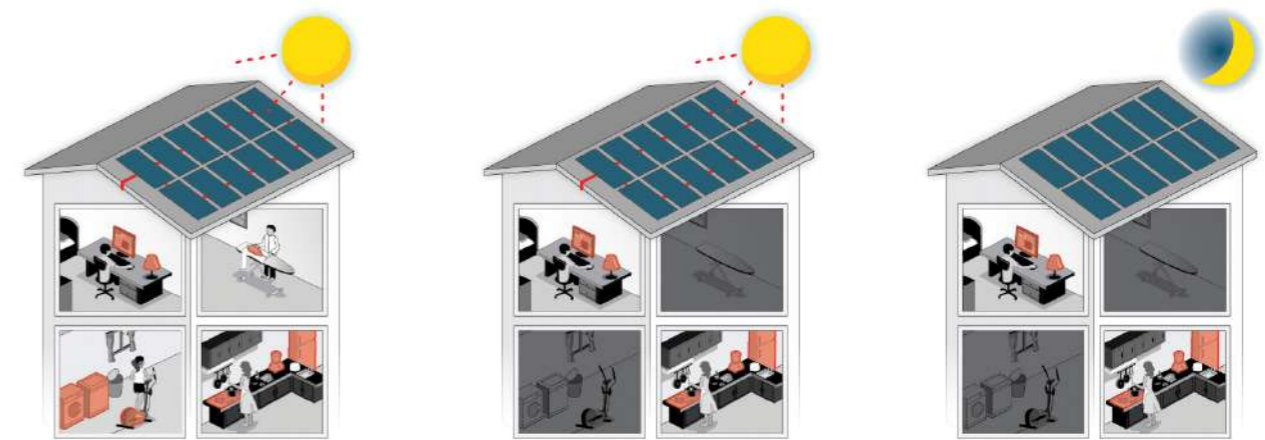

Charge battery from the PV system

Daytime: Important loads are powered first by the PV system and then by the battery. The battery can be charged from the PV as needed

Nighttime: Important loads are powered by the battery

Maximising the Homeowner's Solar Investment with StorEdge

The StorEdge system is full of benefits for the installer and homeowner alike.



More energy

- Power optimisers increase rooftop energy harvest
- PV power is stored directly in the battery; no additional conversions from AC to DC and back to AC
- DC coupled battery solution allows high system efficiency



Simple design and installation

- A single inverter for PV, storage and backup power
- Can be installed in either indoor or outdoor locations
- No special wires are required > utilises the same PV cables
- Supports multiple inverter/battery installations



Full visibility and easy maintenance

- Monitor the battery status, PV production, and self-consumption data
- Smarter energy consumption to reduce electricity bills
- Monitor battery energy levels and remaining hours of backup power
- Remote diagnostics
- Remote firmware upgrades to both inverter and battery



Enhanced safety



- PV array and battery voltage reduced to a safe voltage automatically upon AC shut down when not in backup mode
- Complies with VDE 2100-712 and IEC 60947

PV system with DC-coupled storage

solar**edge**

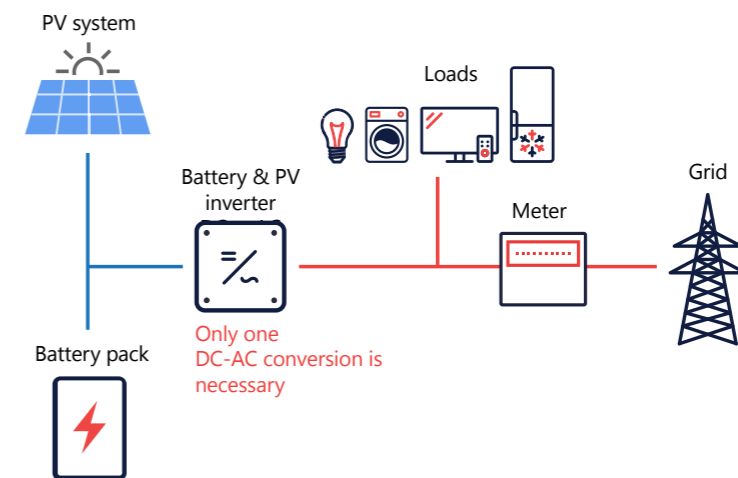

Vs.

PV system with AC-coupled storage

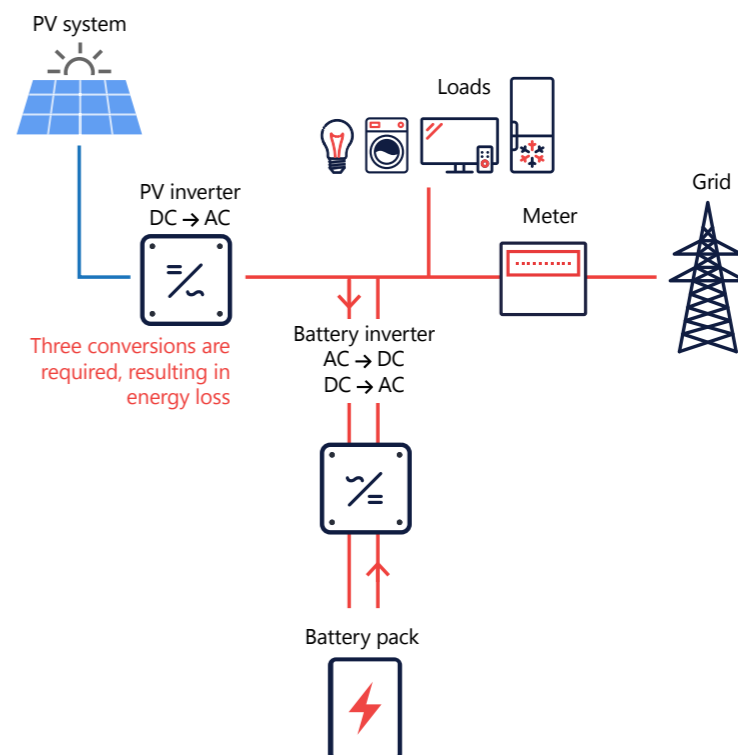

StorEdge DC-Coupled Configuration

Optimising self-consumption + backup power

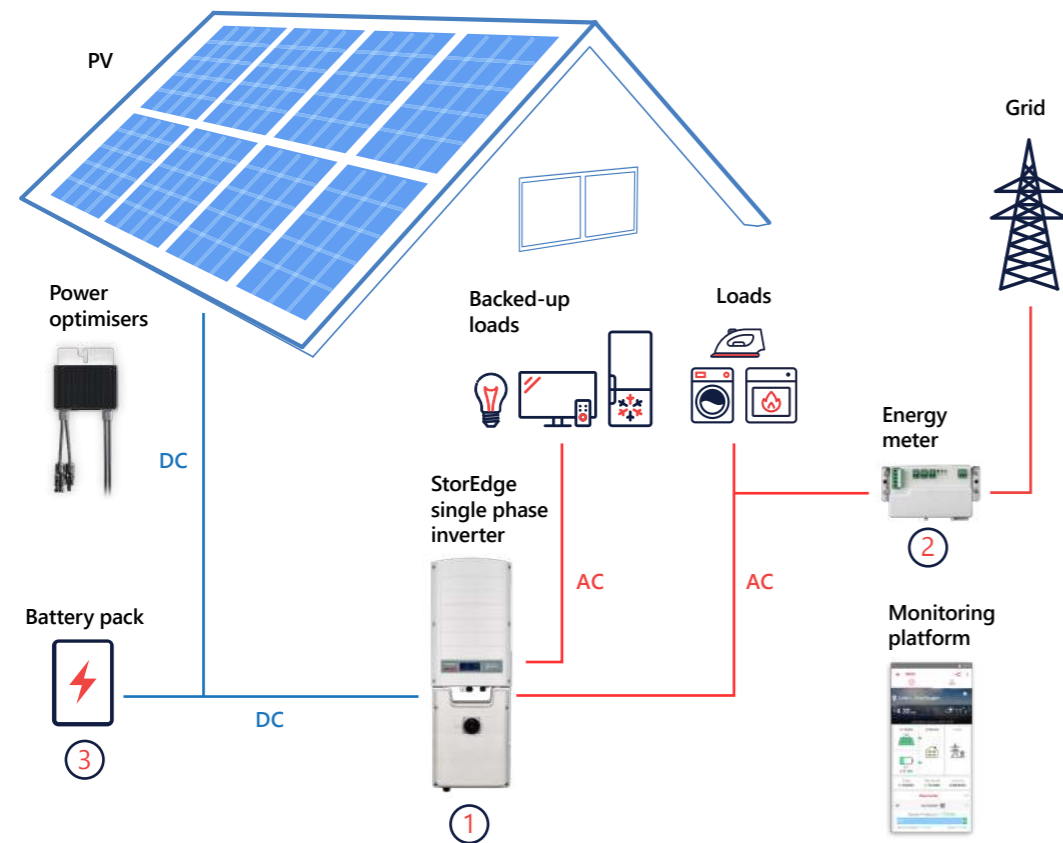

1. StorEdge single phase inverter

The inverter manages battery, system energy and backup power, in addition to its functionality as a PV inverter

2. Energy meter with Modbus connection and current transformers

For measuring electricity import and export
The energy meter is not required for a backup only solution

3. Battery pack

Compatible with DC coupled, high-voltage and high-efficiency batteries from LG Chem



Full Monitoring of PV and StorEdge Systems

The SolarEdge monitoring platform provides insight into household PV production and consumption, displaying the power flow between the PV array, battery, grid and house loads as well as tracking real-time system data.

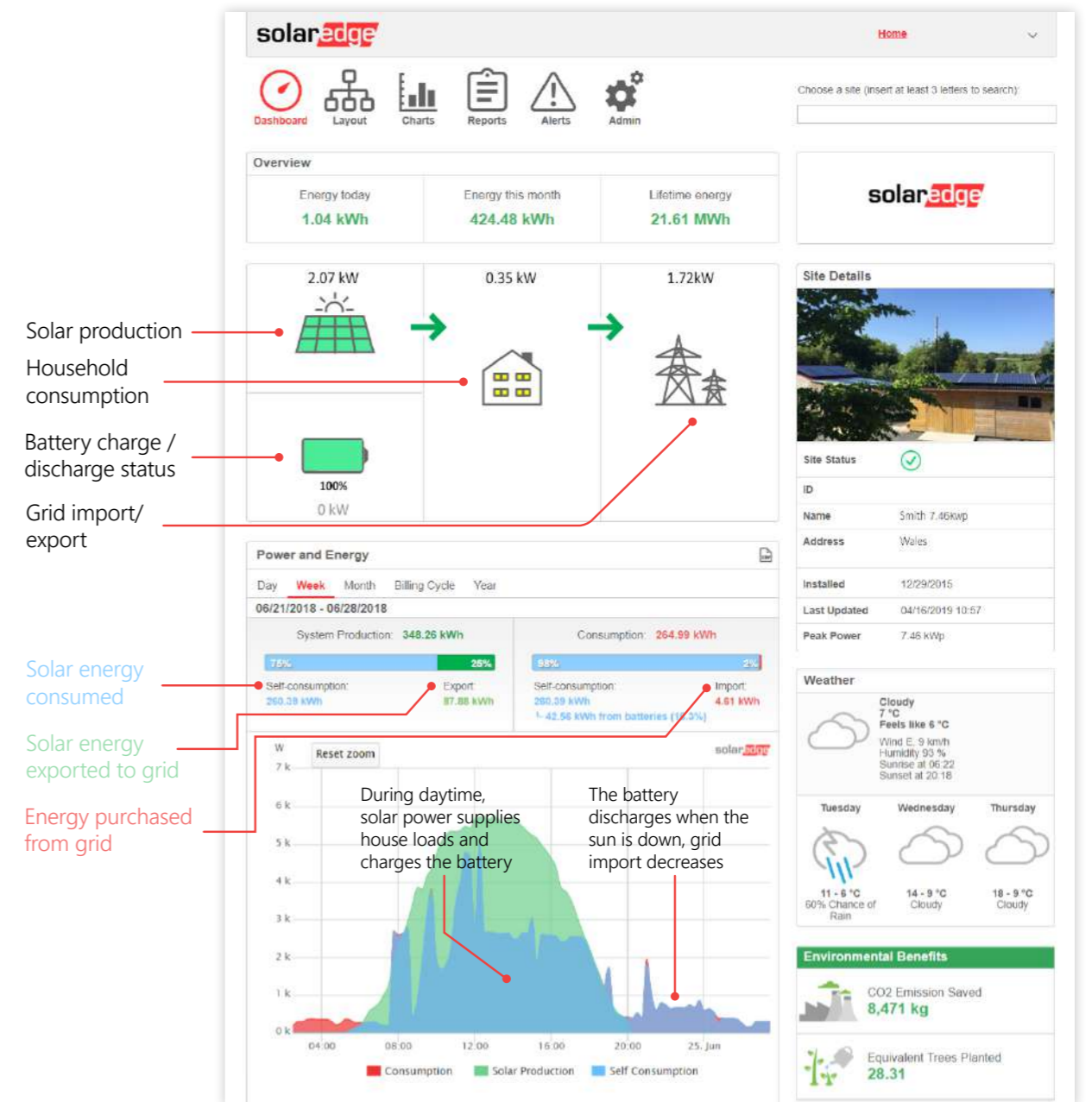

Faster, Easier PV System Design

The Designer is a free web-based tool that helps you lower your PV design costs and close more deals by making more compelling customer proposals. Use the online tool to plan, build and validate your SolarEdge systems from inception to installation.

Access the Designer platform via the **Login menu** on the SolarEdge homepage.

Save time and money

- Supports satellite or custom site imagery – no need for a site visit prior to initial design
- Free for use - no license or subscription fees required
- Maximise roof utilisation and enjoy SolarEdge design flexibility advantages with instant validation
- Eliminate costly installation mistakes by creating visual wiring diagrams of your PV system



Close more deals

- Impress your customers with a visually attractive 3D simulation of their roof
- Make quick, on-the-fly design modifications based on homeowner feedback
- Offer more compelling customer proposals with Designer's comprehensive reports and accurate energy simulations



Enjoy a modern, intuitive platform

- Clean, interactive, graphical interface
- Web-based access from any Mac or PC
- Multi-user access to your Designer account for easy project collaboration
- Automatic upgrades — no need to install new versions or download datasets



Working with SolarEdge

SolarEdge offers its PV installers valuable services to help make your experience positive and efficient.

Support

Comprehensive pre and post-sale technical services include technical documentation, personal project-based technical consulting, and more. Do not hesitate to contact the SolarEdge support team with for technical or service support. Simply open a case via the Support tab of your SolarEdge monitoring dashboard or the SolarEdge website **Support** page.

Training

Expand your knowledge of SolarEdge products and solutions. The SolarEdge website **Training** page links directly to webinars and E-learning courses. There you'll also find registration links to SolarEdge training seminars taking place in a location near you.

Alliance program

Welcome to the Alliance program where you can accumulate 15 points for every kW of SolarEdge systems that you register on the monitoring platform. Redeem your points for promotional materials or gifts, perfect for company employees or family members.

Redeem points by accessing your **Alliance account** via the SolarEdge website.

Marketing tools

Access marketing collateral to help you sell SolarEdge solutions: visit the SolarEdge website **Downloads Center** to access product catalogs, brochures, case studies, datasheets and more.

Contact your local SolarEdge sales or marketing person for more information about marketing and support services.



SolarEdge at home



Solar energy makes you strong



Teamwork to take this roof solar



Residential Product Offering

CLICK ONE OF THE RED ICONS TO LEARN MORE ABOUT EACH PRODUCT
To view online, scan the QR code or copy the link: solaredge.com/offering-IND



Complete residential PV solutions





-  Video
-  Installer catalog
-  Homeowner brochure

Inverters

- / Single phase inverters with HD-Wave technology: 4kW-5kW
- / Three phase inverters: 5kW-10kW



-  Video
-  Single phase inverter datasheet
-  Three phase inverter datasheet

Power optimisers

Module-level optimisation P300-P505



-  Datasheet

Monitoring platform

- / Free, real-time system visibility at the module level
- / Dedicated mobile apps for installers and system owners





-  Monitoring video for installers
-  Monitoring video for homeowners
-  mySolarEdge video

Designer

Online tool to plan, build and validate your SolarEdge systems from inception to installation



-  Designer overview video
-  Create residential projects video

StorEdge® solution

Maximises self-consumption and provides backup power when grid is down



-  Brochure
-  StorEdge inverter (backup) datasheet

Single phase inverters with compact technology

For small rooftop systems of 4-8 modules





-  Brochure
-  Datasheet

Wireless communication

Multiple options for wireless connection of inverters to the internet e.g. for monitoring



-  Cellular plug-in datasheet
-  Wi-Fi/ZigBee external antenna datasheet

Energy meter and current transformers

Supports high accuracy production/consumption monitoring, and export limitation



-  Datasheet

SolarEdge is a global leader in smart energy technology. By leveraging world-class engineering capabilities and with a relentless focus on innovation, SolarEdge creates smart energy solutions that power our lives and drive future progress.

SolarEdge developed an intelligent inverter solution that changed the way power is harvested and managed in photovoltaic (PV) systems. The SolarEdge DC optimised inverter maximises power generation while lowering the cost of energy produced by the PV system.

Continuing to advance smart energy, SolarEdge addresses a broad range of energy market segments through its PV, storage, EV charging, UPS, and grid services solutions.

 SolarEdge

 @SolarEdgePV

 @SolarEdgePV

 SolarEdgePV

 SolarEdge

 infoIND@solaredge.com

solaredge.com

© SolarEdge Technologies, Ltd. All rights reserved. SOLAREEDGE, the SolarEdge logo, OPTIMIZED BY SOLAREEDGE are trademarks or registered trademarks of SolarEdge Technologies, Inc. All other trademarks mentioned herein are trademarks of their respective owners. Date: 06/2020/V01/EN IND. Subject to change without notice.

This document includes estimates of various parameters of the compared solar systems, including annual A/C energy production, performance ratio and shading loss based on PVsyst computer-simulated results for installations using our and competing systems. While we are not aware of any reason to believe these estimates and comparisons are materially inaccurate or misleading, they are inherently uncertain and the projected results are not guaranteed. Actual results will vary depending on a number of factors, including actual field conditions, quality of instalment and other variances from the assumptions underlying the estimates. Although care has been taken to ensure the accuracy, completeness and reliability of the estimates and comparisons presented, SolarEdge assumes no responsibility for these. MORE SPECIFICALLY, IN NO EVENT SHALL SOLAREEDGE BE LIABLE FOR ANY DIRECT, INDIRECT, SPECIAL OR INCIDENTAL LOSSES OR DAMAGES RESULTING FROM OR ARISING OUT OF USE OF OR RELIANCE ON THE ESTIMATES AND COMPARISONS PRESENTED.

 solar**edge**

